

Eclipse ThermJet

Burners

Model TJ0200

Version 2

Parameter	Burner Velocity	Model TJ0200	
Maximum Input BTU/hr (kW)	Medium & High Velocity	2,000,000 (586)	
Minimum Input, On-Ratio BTU/hr (kW)	Medium & High Velocity	200,000 (59)	
Minimum Input, Fixed Air BTU/hr (kW)	Medium & High Velocity	40,000 (12)	
Gas Inlet Pressure Required "w.c. (mbar) Fuel Pressure at Gas Inlet (Tap "B" - see page 3)	High Velocity	Natural Gas	9.3 (23.0)
		Propane	12.7 (32.0)
		Butane	13.4 (34.0)
	Medium Velocity	Natural Gas	7.1 (18.0)
		Propane	8.5 (21.0)
		Butane	6.9 (17.0)
Air Inlet Pressure Required "w.c. (mbar) 15% Excess Air at Maximum Input (Tap "A" - see page 3)	High Velocity	Natural Gas	12.3 (31.0)
		Propane	14.1 (35.0)
		Butane	14.1 (35.0)
	Medium Velocity	Natural Gas	10.0 (25.0)
		Propane	11.0 (28.0)
		Butane	11.0 (28.0)
High Fire Flame Length Inches (mm) (Measured from End of Combustor)	High Velocity	Natural Gas	27 (685)
		Propane	30 (760)
		Butane	30 (760)
	Medium Velocity	Natural Gas	36 (915)
		Propane	32 (810)
		Butane	32 (810)
Maximum Flame Velocity ft/s (m/s) 15% Excess Air at Maximum Input	High Velocity	500 (152.4)	
	Medium Velocity	250 (76.2)	
Maximum Combustion Air Temperature	300°F (149°C). For higher temperatures, use TJPCA (Data 206).		
Flame Detection	UV scanner and flamerod available for all combustors for application under 2,200°F (1,204°C). Flamerod available for use with alloy or silicon carbide combustors only. Certain piping configurations prohibit the use of a flamerod, see page 3 for details.		
Fuel	Natural gas, propane, or butane. For any other mixed gas, contact Eclipse for orifice sizing.		
Approvals			

- All information is based on laboratory testing in neutral (0.0" w.c.) pressure chamber. Different chamber size and conditions may affect the data.
- All information is based on standard combustor design. Changes in combustor will alter performance and pressures.
- All inputs based upon gross calorific values.
- Eclipse reserves the right to change the construction and/or configuration of our products at any time without being obliged to adjust earlier supplies accordingly.
- Plumbing of air and gas will affect accuracy of orifice readings. All information is based on generally acceptable air and gas piping practices.

Performance Graphs

Ignition & Operational Zones

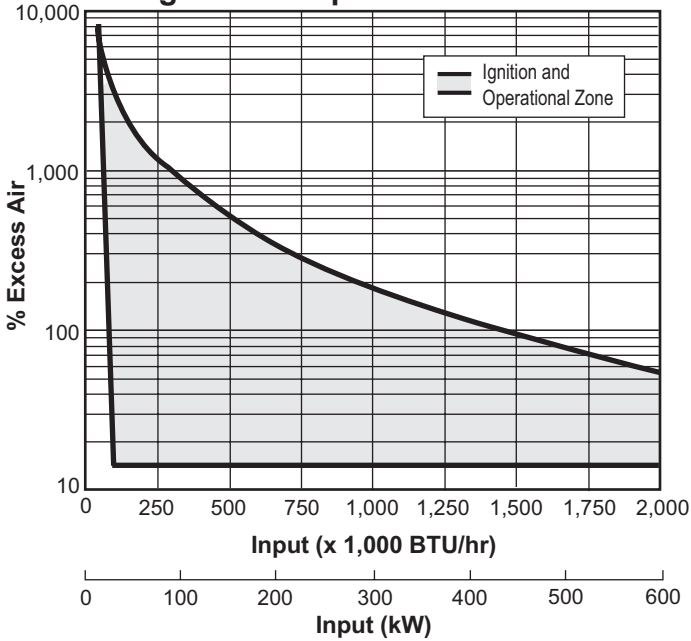

NO_x Emissions (High Velocity Combustor)

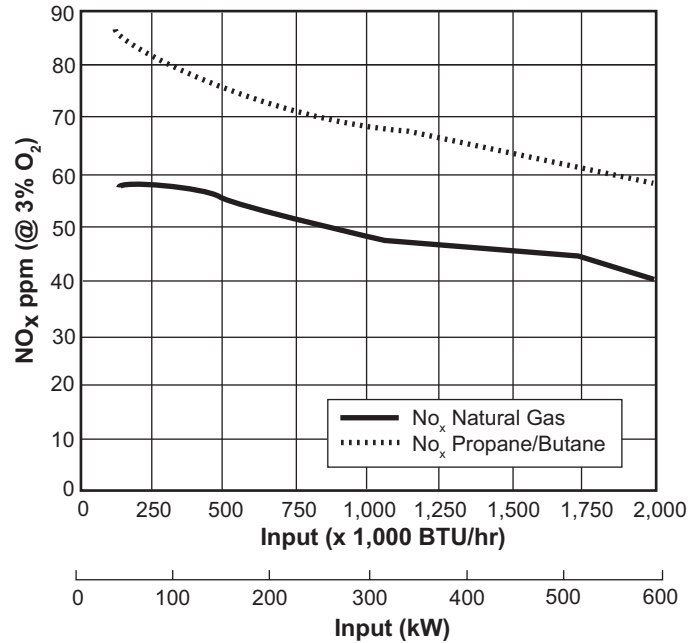

Correction factor for medium velocity combustor is 1.20. Emissions data based on on-ratio control, firing 15% excess air, corrected to 3% O₂.

Emissions from the burner are influenced by:

- Fuel type
- Combustion air temperature
- Firing rate
- Chamber conditions
- Percent of excess air

For estimates of other emissions, contact Eclipse.

Gas Orifice ΔP vs. Input (Measured from Tap B to Tap D)

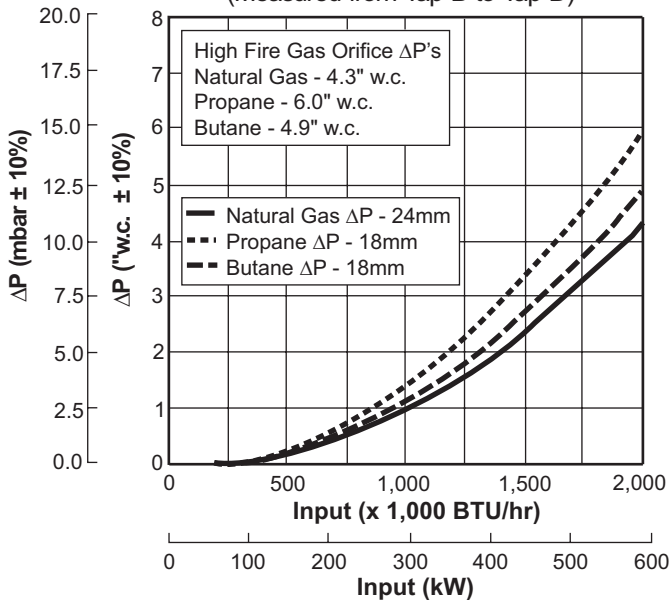

Air Orifice ΔP vs. Input

(Measured from Tap A to Tap C)
15% Excess Air at Maximum Input

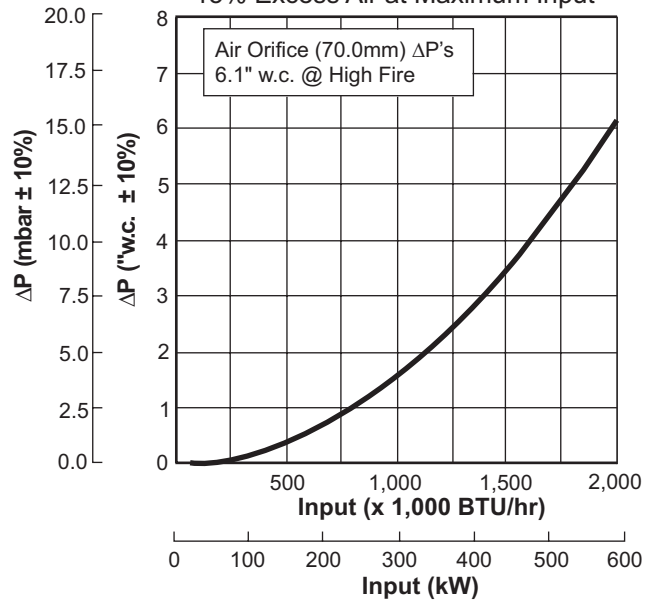

Dimensions in inches (mm)

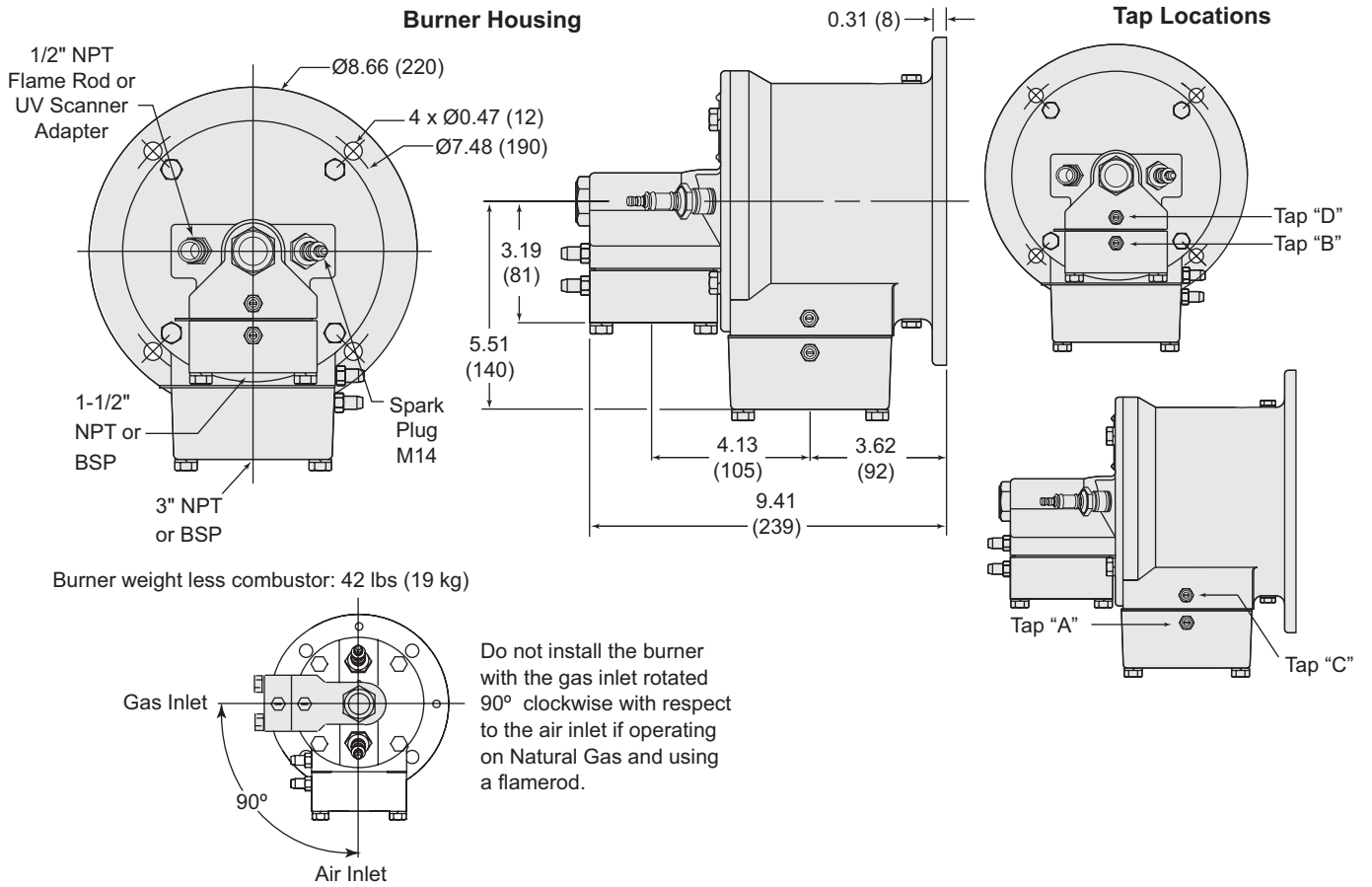

Combustor

Exhaust Outlet Diameter: Medium Velocity \varnothing 4.13 (105)

High Velocity \varnothing 3.34 (85)

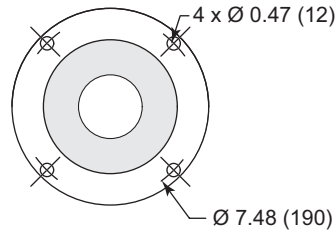
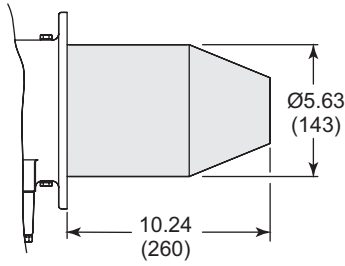

Alloy Tube (AISI 310)

Weight: 4.2 lbs (1.9 kg)

Maximum Chamber Temp: 1,750°F (940°C)

(Not suitable for preheated air over 700°F)

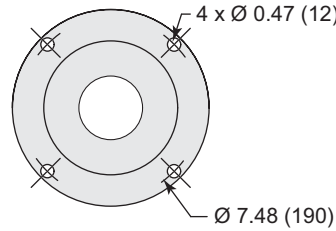
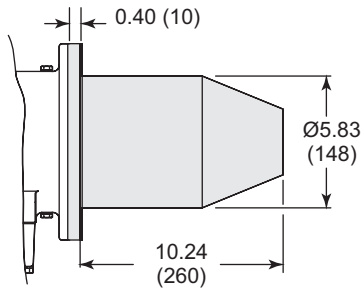

Silicon Carbide Tube

Weight: 3.1 lbs (1.5 kg)

Maximum Chamber Temp: 2,200°F (1200°C)

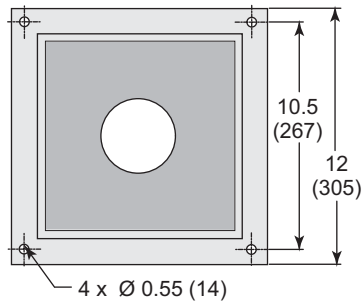
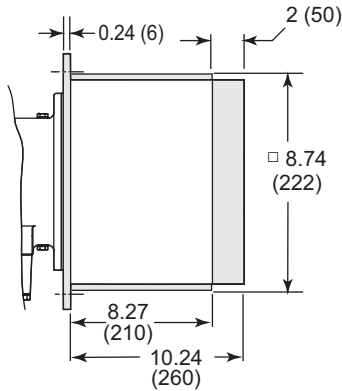

Refractory Block

(w/330 SS Wrapper)

Weight: 66 lbs (30 kg)

Maximum Chamber Temp: 2,800°F (1538°C)

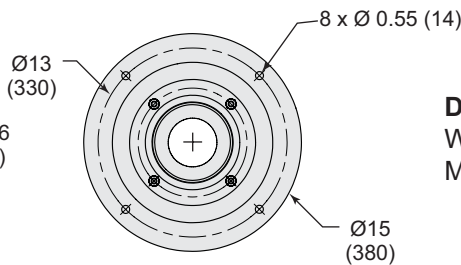
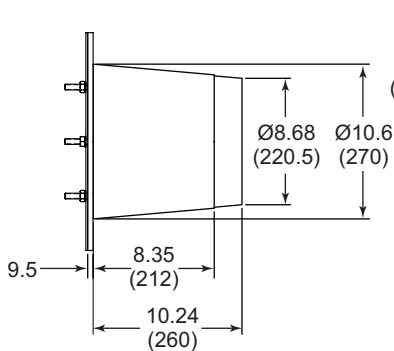

Down-Firing Block

Weight: 77 lbs (35 kg)

Max. Chamber Temp: 2800°F (1535°C)



Offered By:

Power Equipment Company
2011 Williamsburg Road
Richmond, Virginia 23231
Phone (804) 236-3800
Fax (804) 236-3882

www.peconet.com